

SF-G on air conditioners



These are two different cases where multiple SF-G inverters are installed to save energy.

Requirements:

For the first case:

1. There is a controller sending I/O to start and 4 to 20 mA signal to control the frequency.
2. A constant speed button, and a terminal to receive I/O signal from controller to switch frequency source.

Second case:

1. There is a controller sending I/O to start and 0 to 10 volts signal to control the frequency.
2. Output 0~10V to indicate operating frequency.

Wiring diagram:

First case:

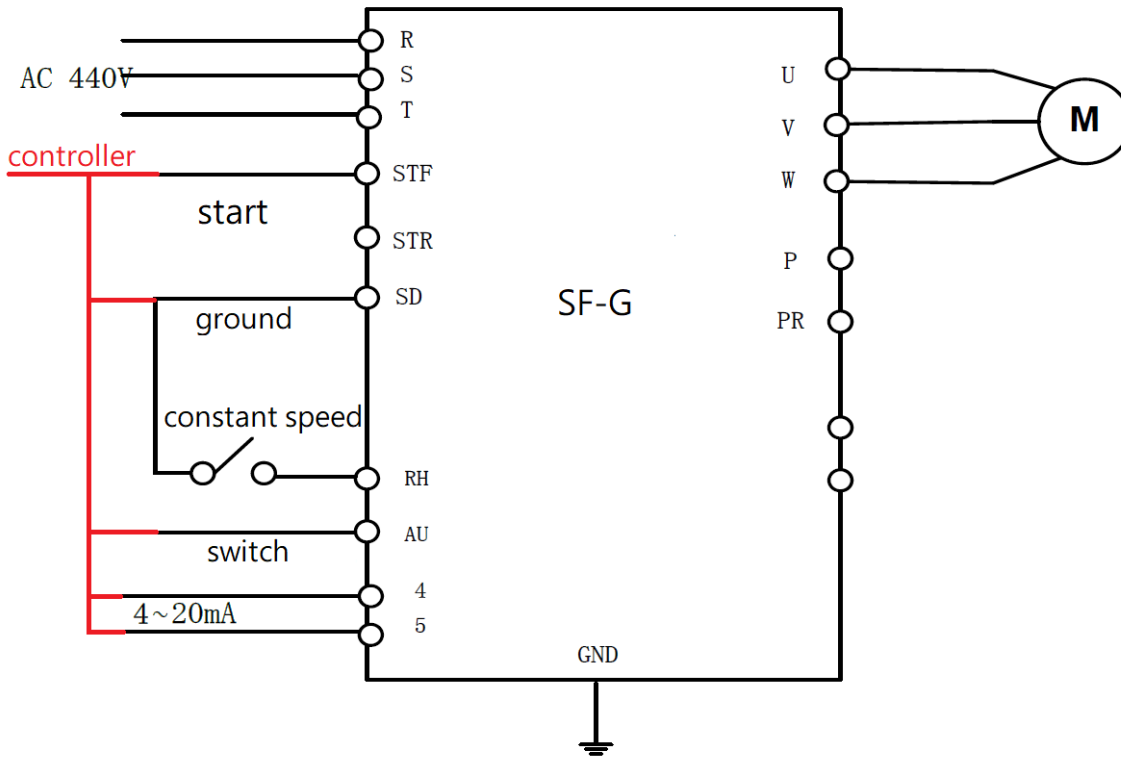

STF and AU terminal are wired to controller to start and switch frequency source between button and current signal. The current signal is connected to terminal 4 5.

Second case:

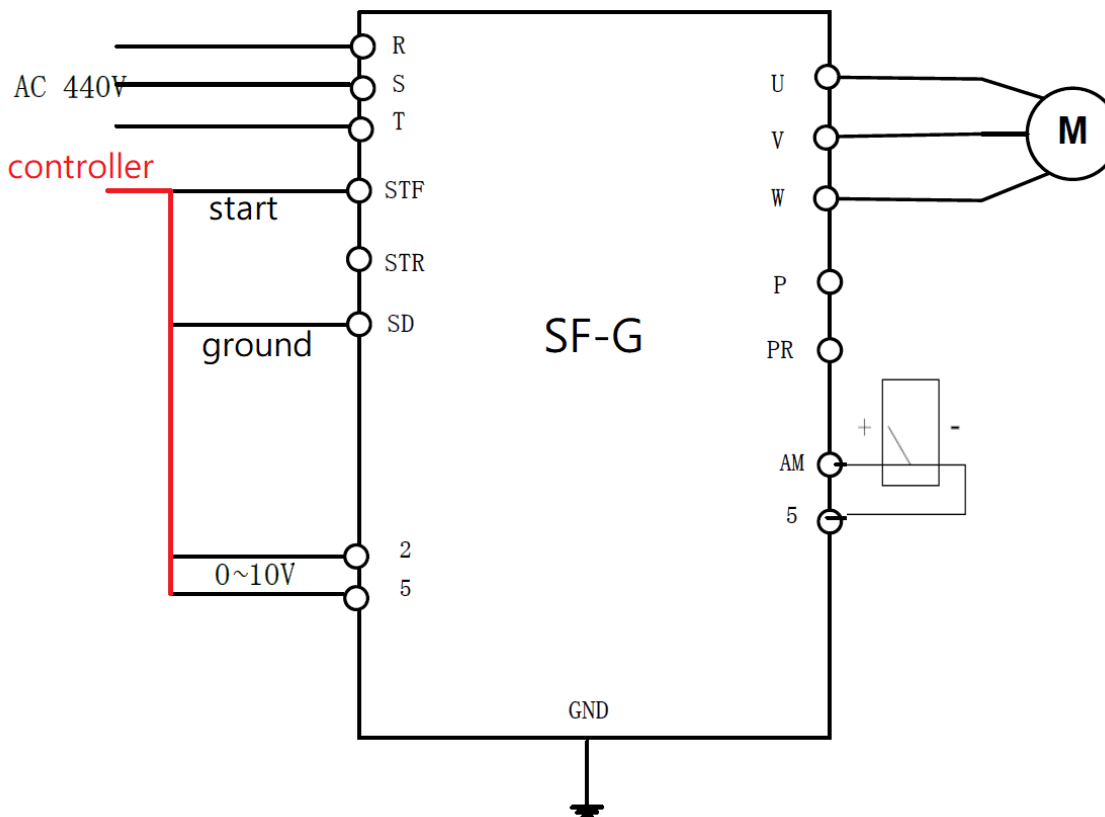

The voltage signal and start terminal is wired to the controller, and we wired a voltmeter to terminal 5 AM to indicate operating frequency.

Photo:

First case



Second case



Parameters changed:

First case:

Number	Name	Setting range	Default value	Set value
P.4	High speed	0~400Hz	60Hz	40Hz

We set constant speed 40Hz on P.4 for terminal RH.

Second case:

Number	Name	Setting range	Default value	Set value
P.2	Min frequency	0~120Hz	0Hz	30Hz
P.73	Input voltage range	0(0~5V) 1(0~10V)	0	1

We set a minimum frequency 30Hz so the frequency won't drop under 30 Hz, and set P.73 to 1 to meet the requirement.